

## ELECTRICAL GAUGES REMOTE CONTROLLER SERIES

### SMOKE LENS & ANGEL RING GAUGE WHITE / BLUE / AMBER LED DISPLAY

# Air fuel / ratio

## OPENING CEREMONY

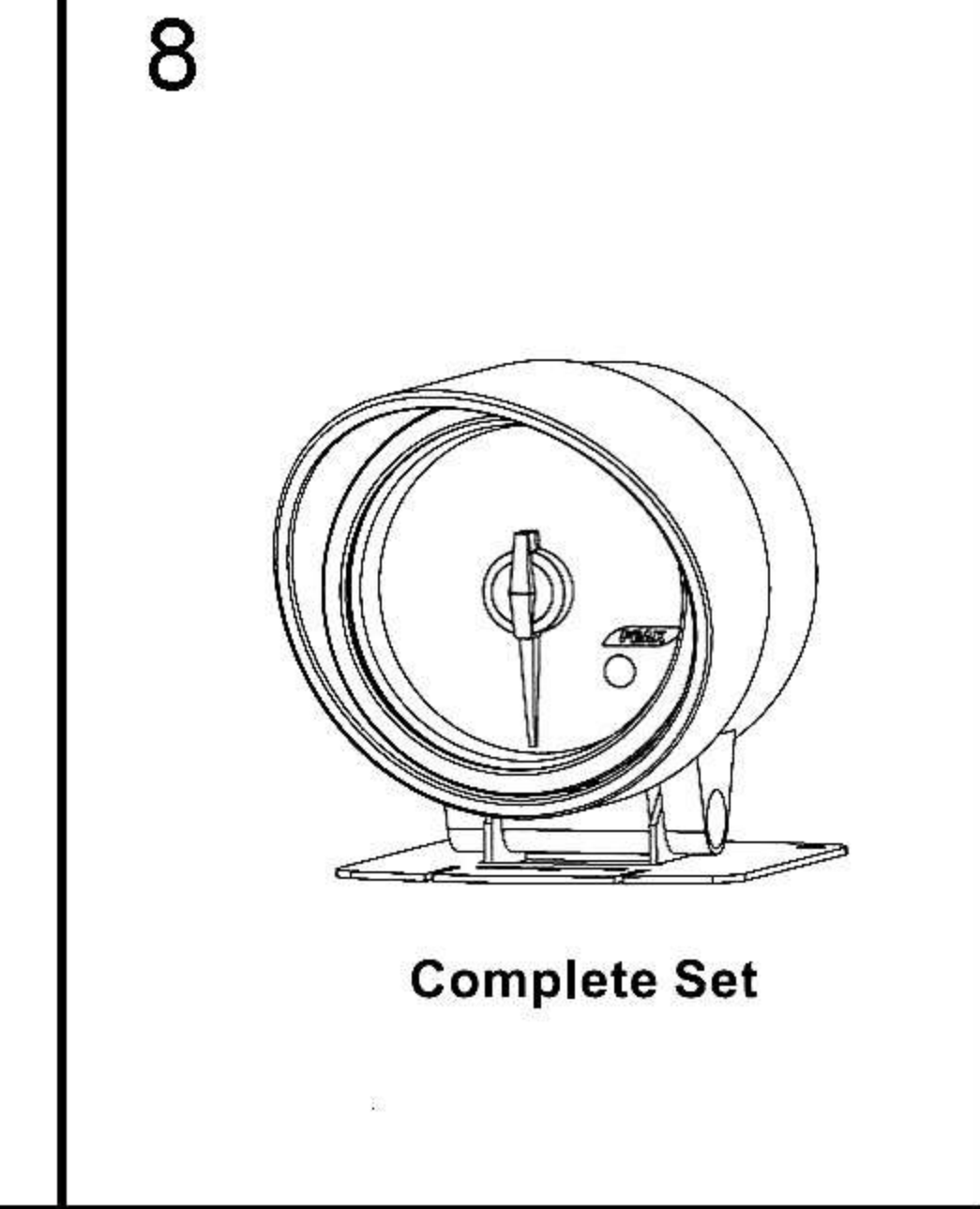
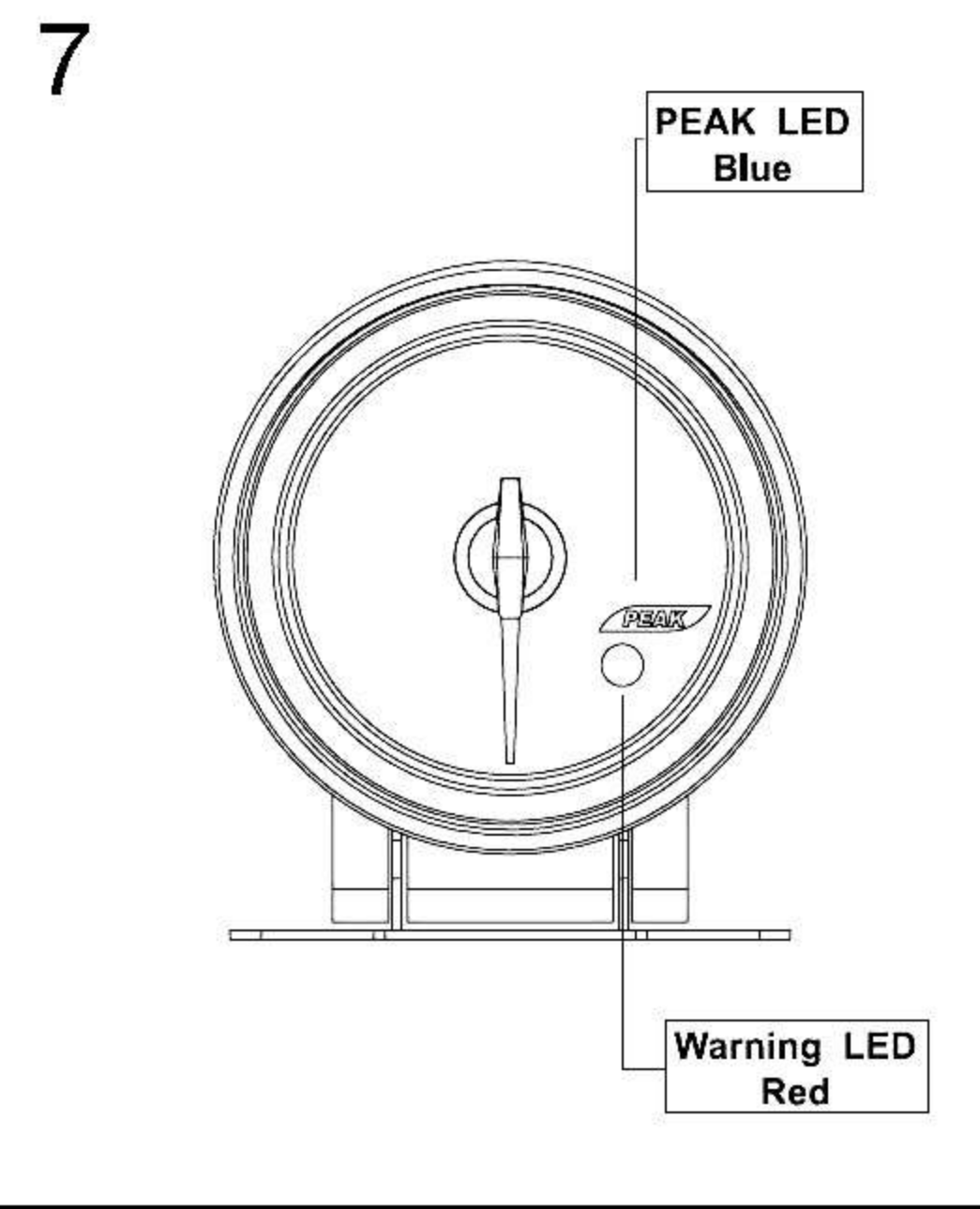
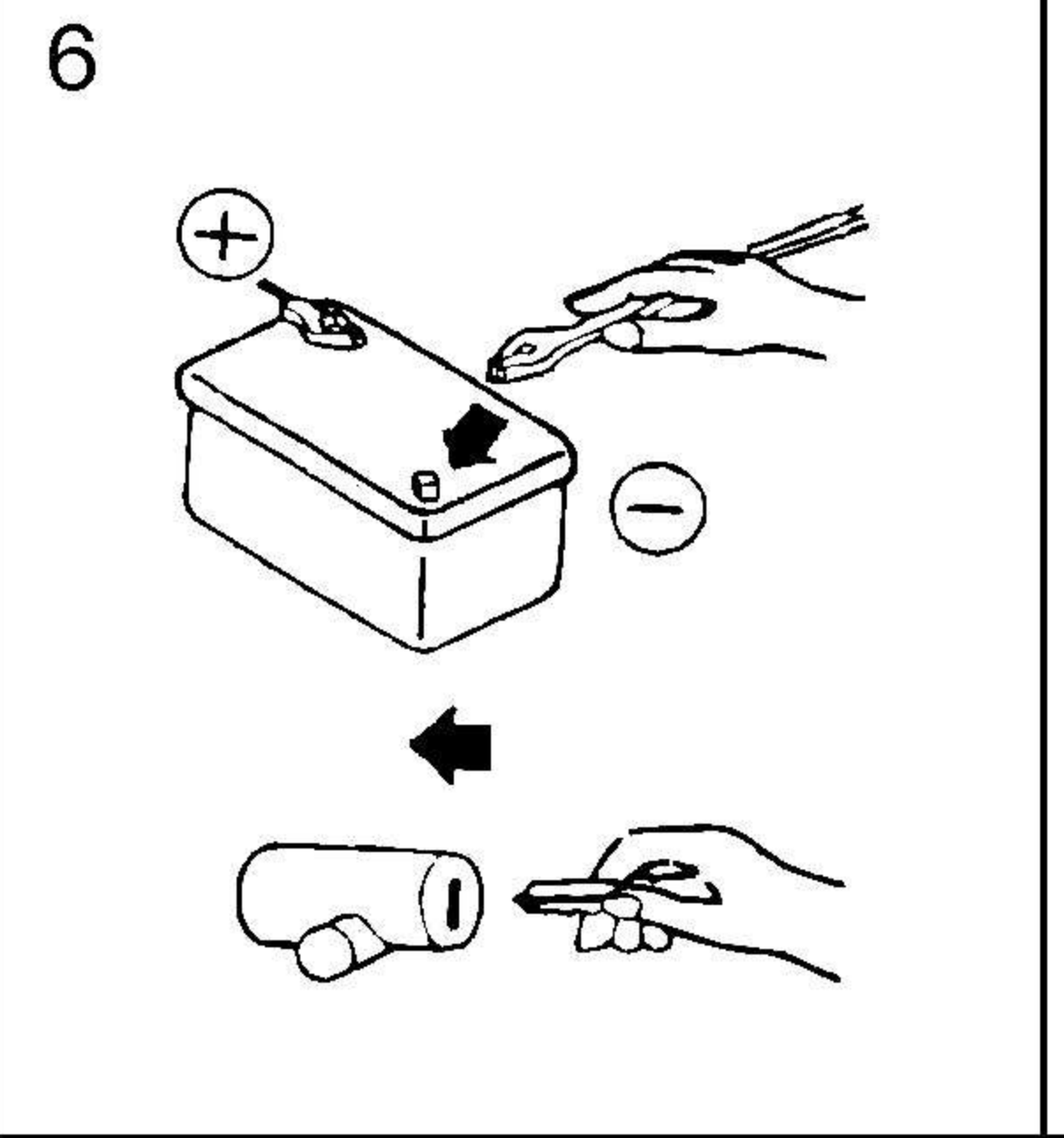
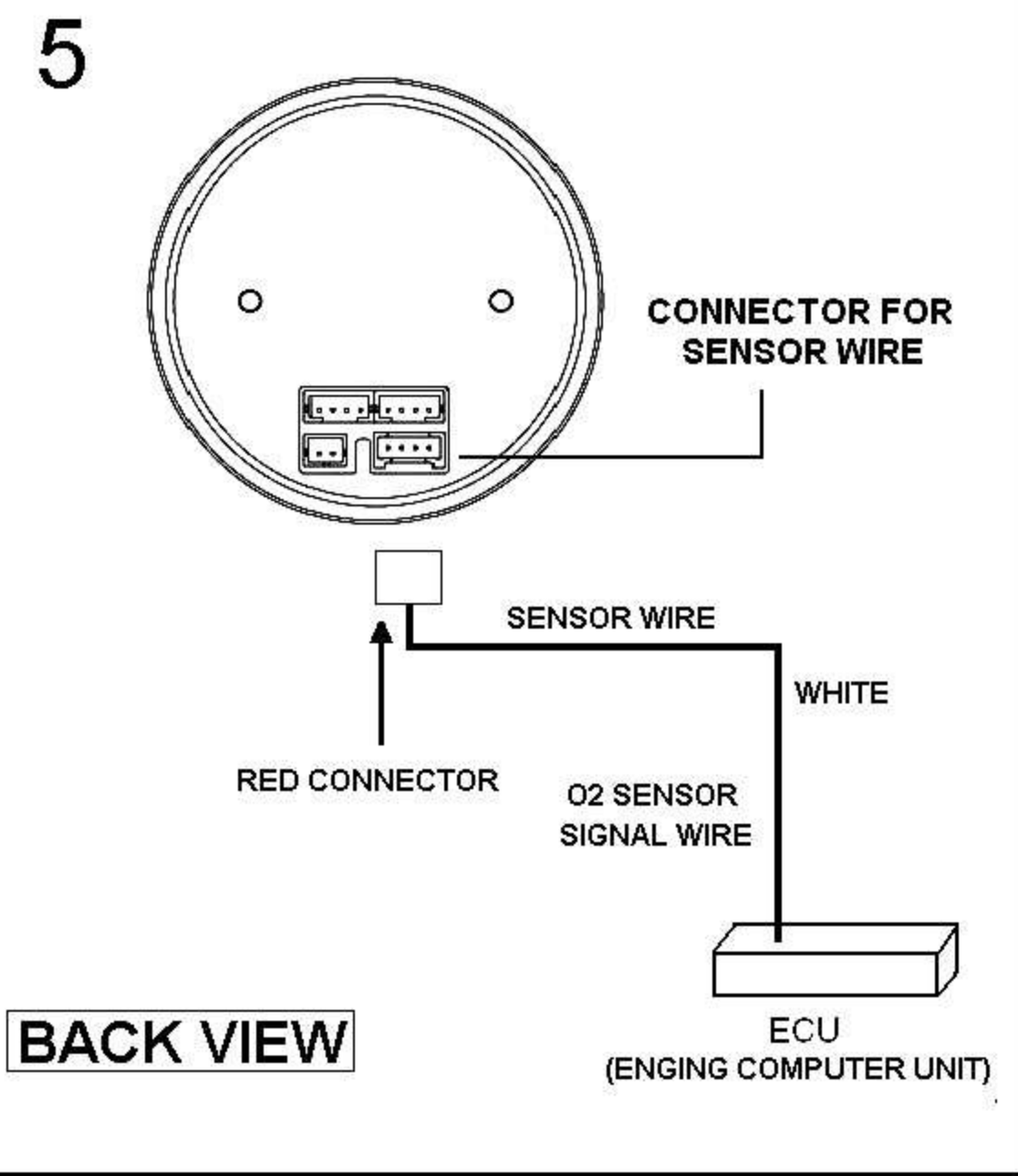
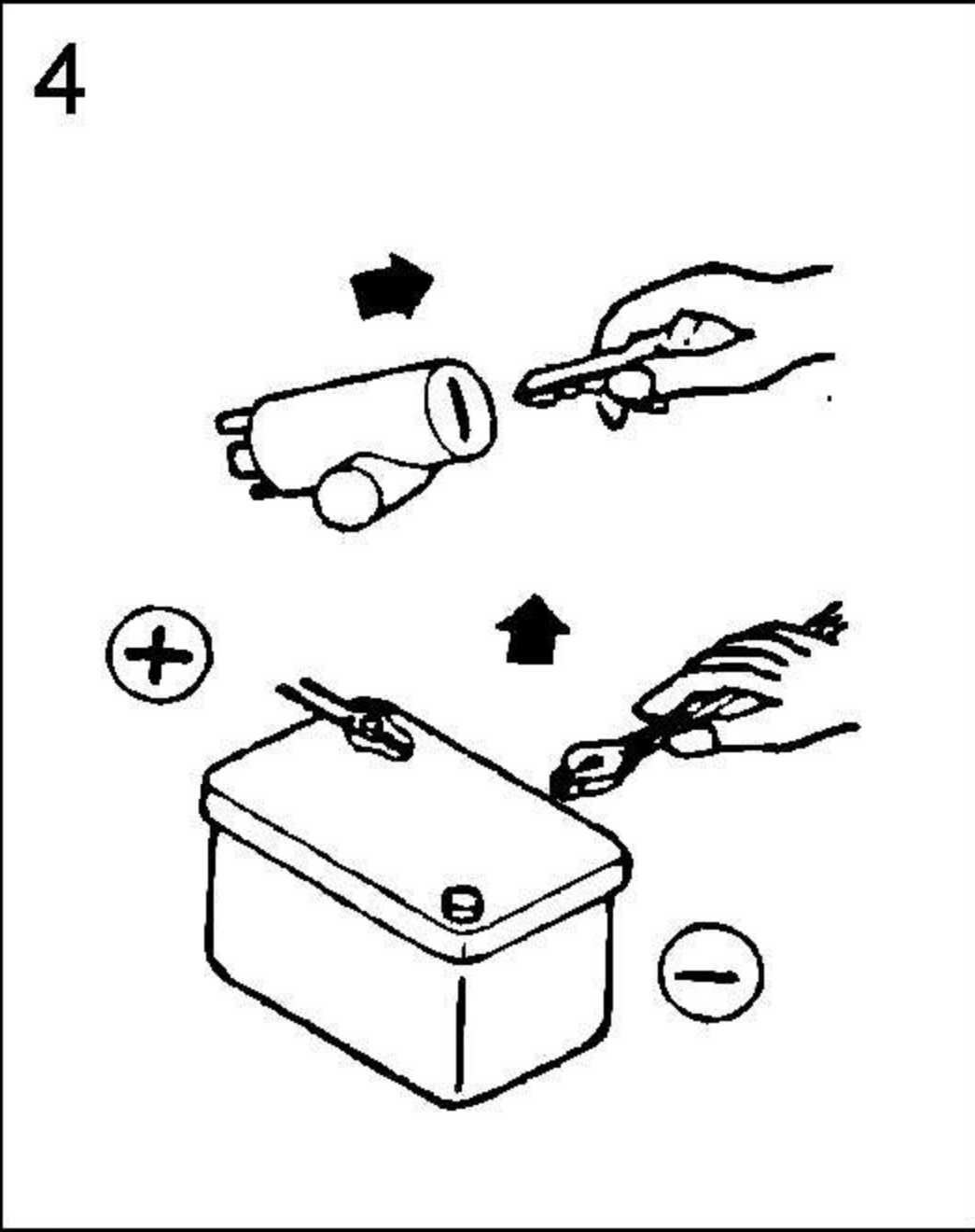
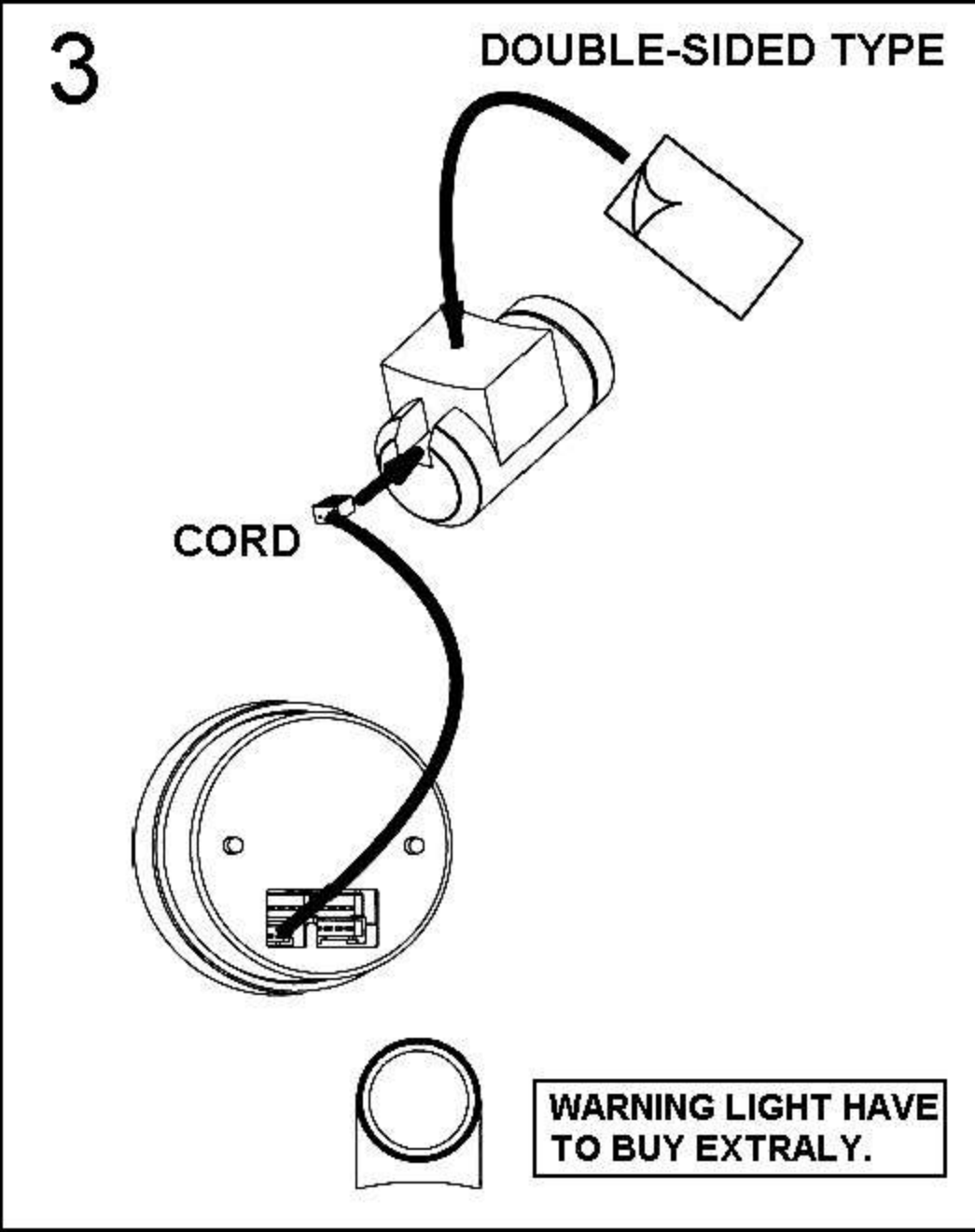
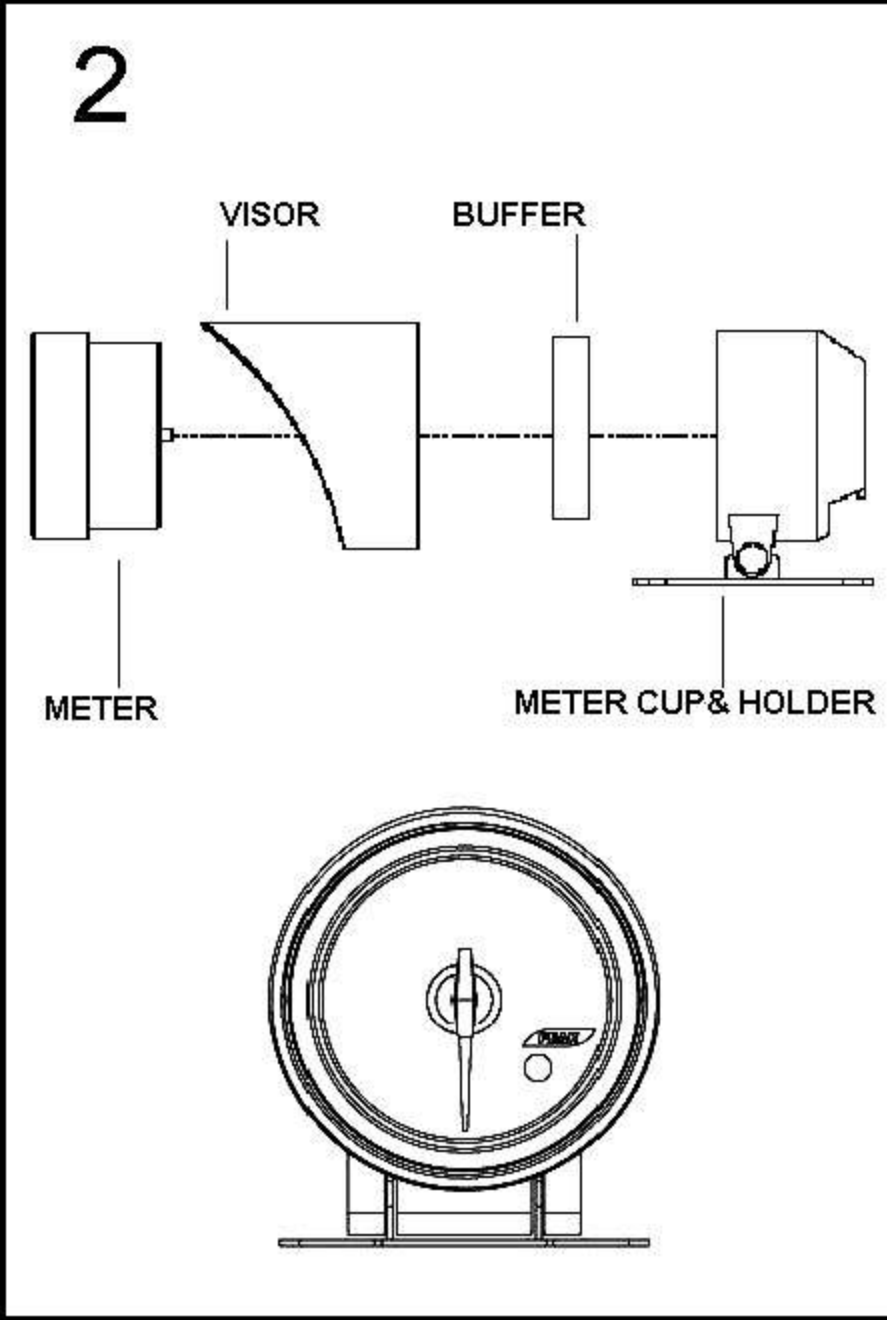
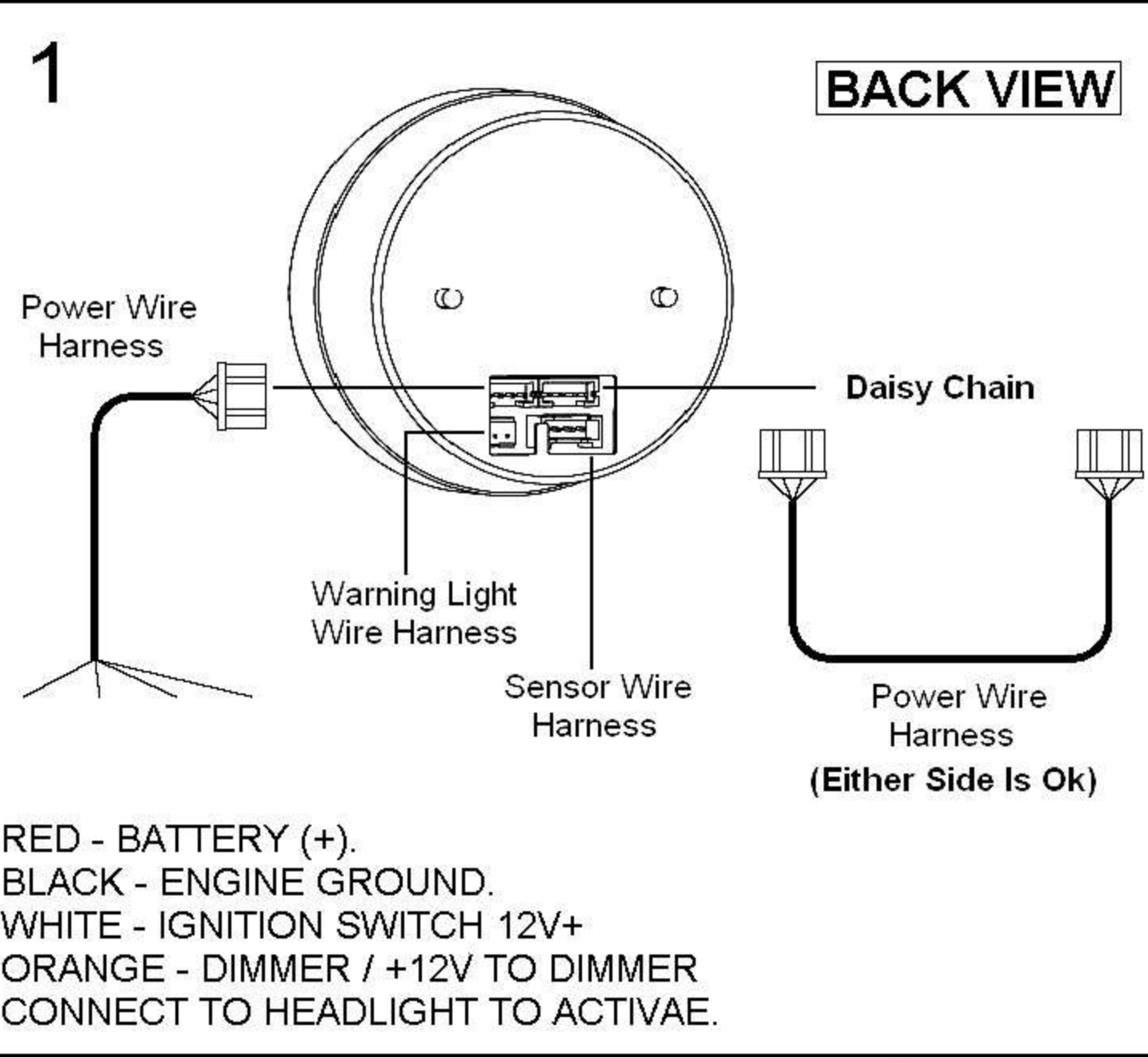

# Boost / Vacuum Gauge

## OPENING CEREMONY

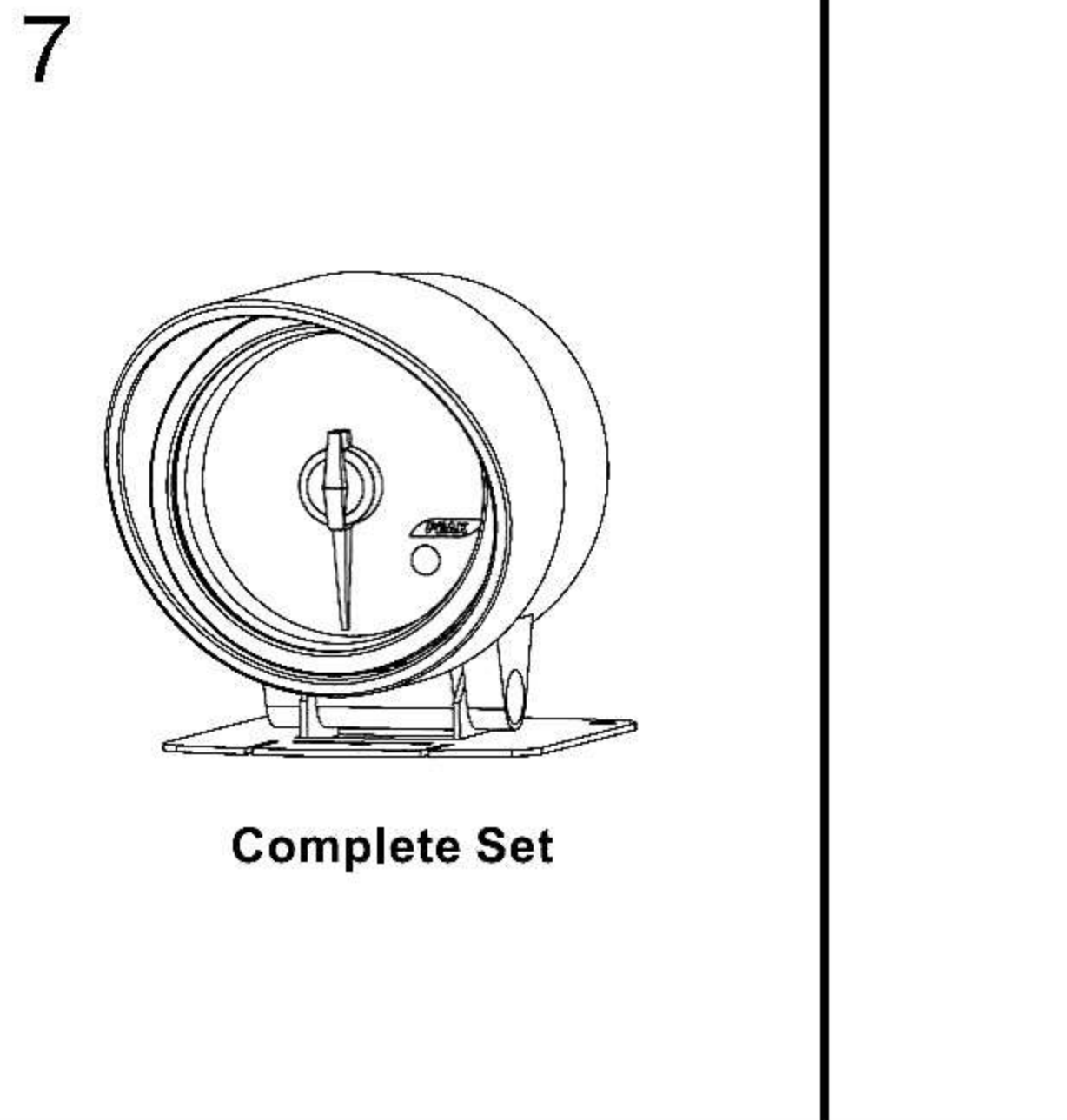
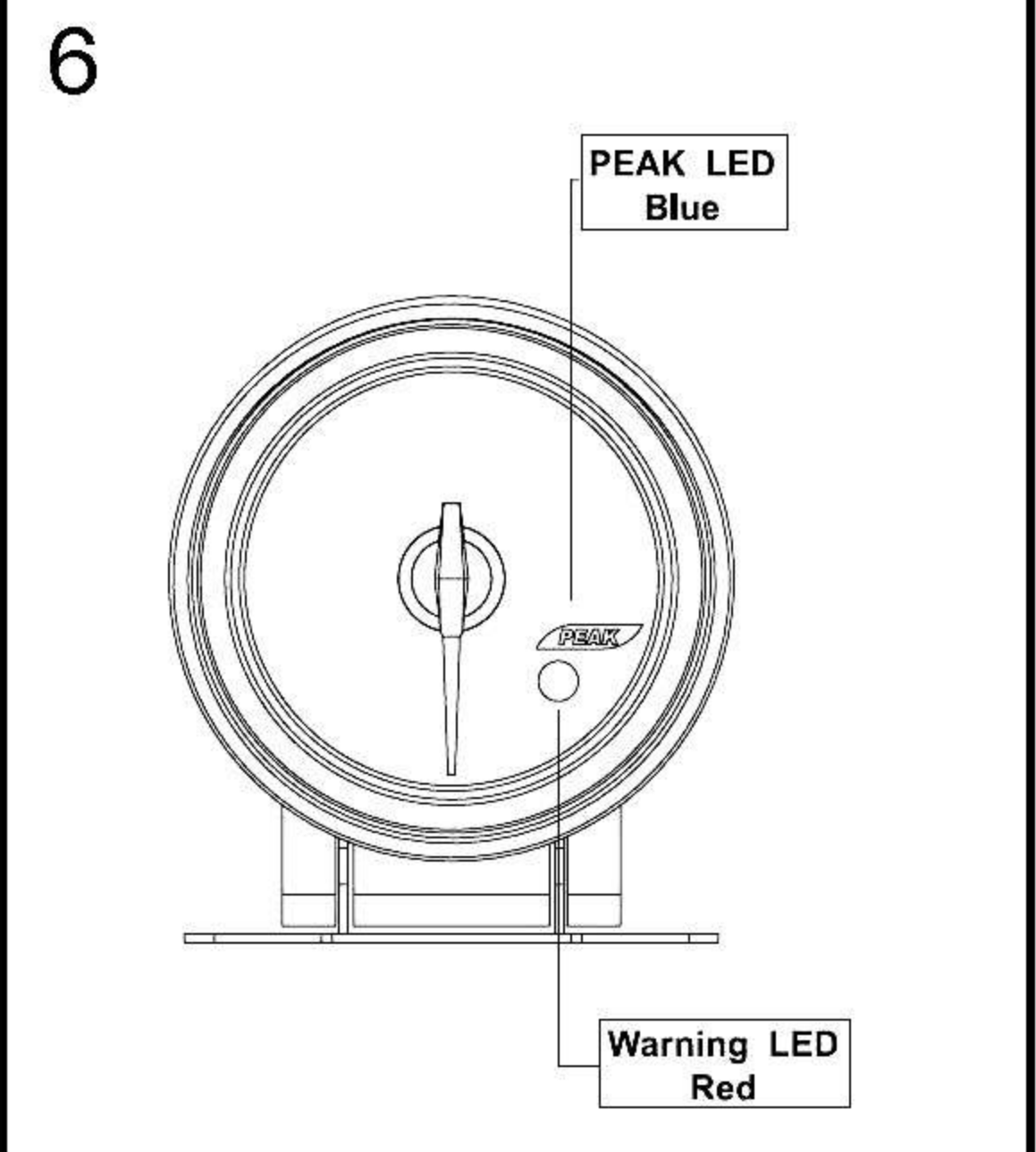
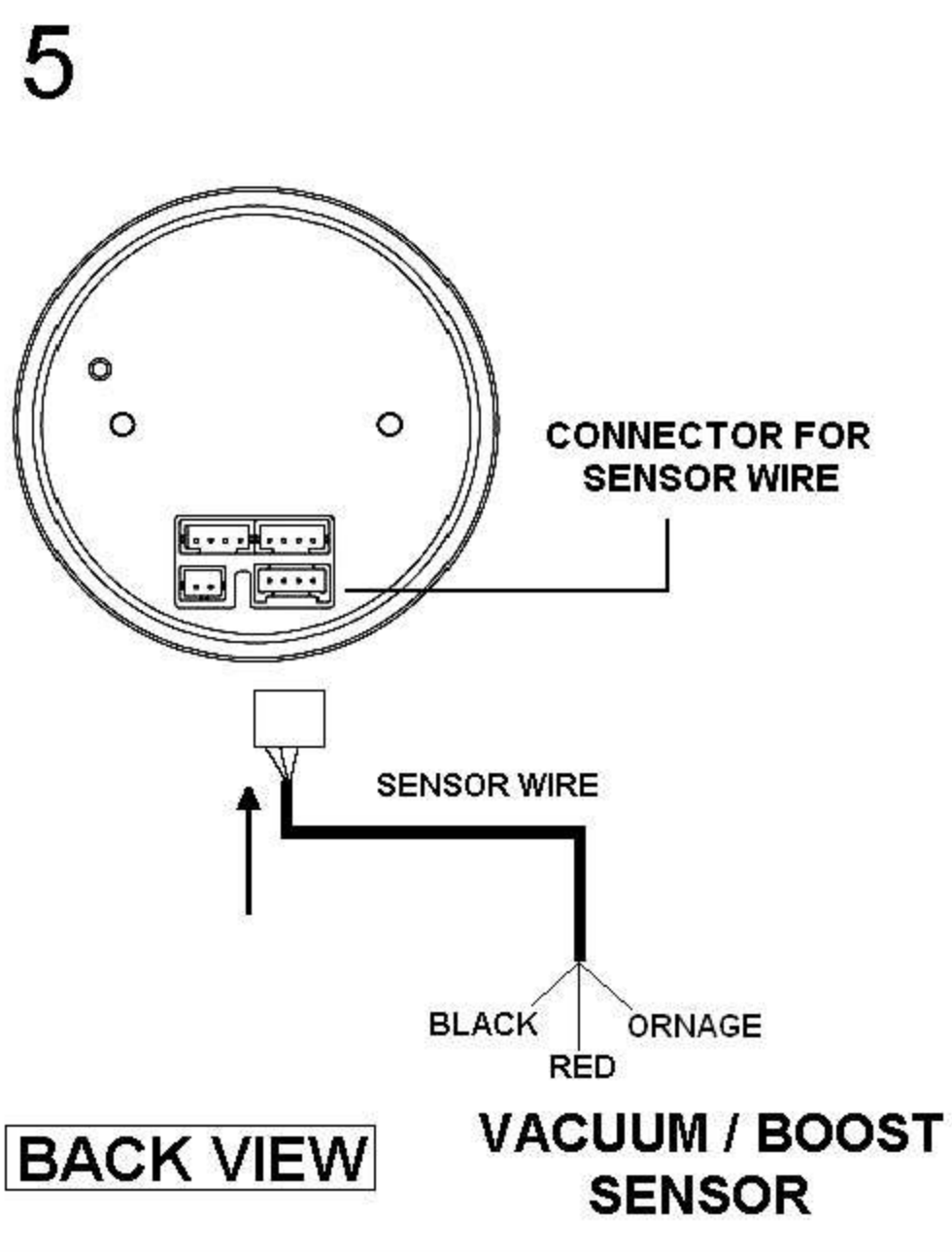
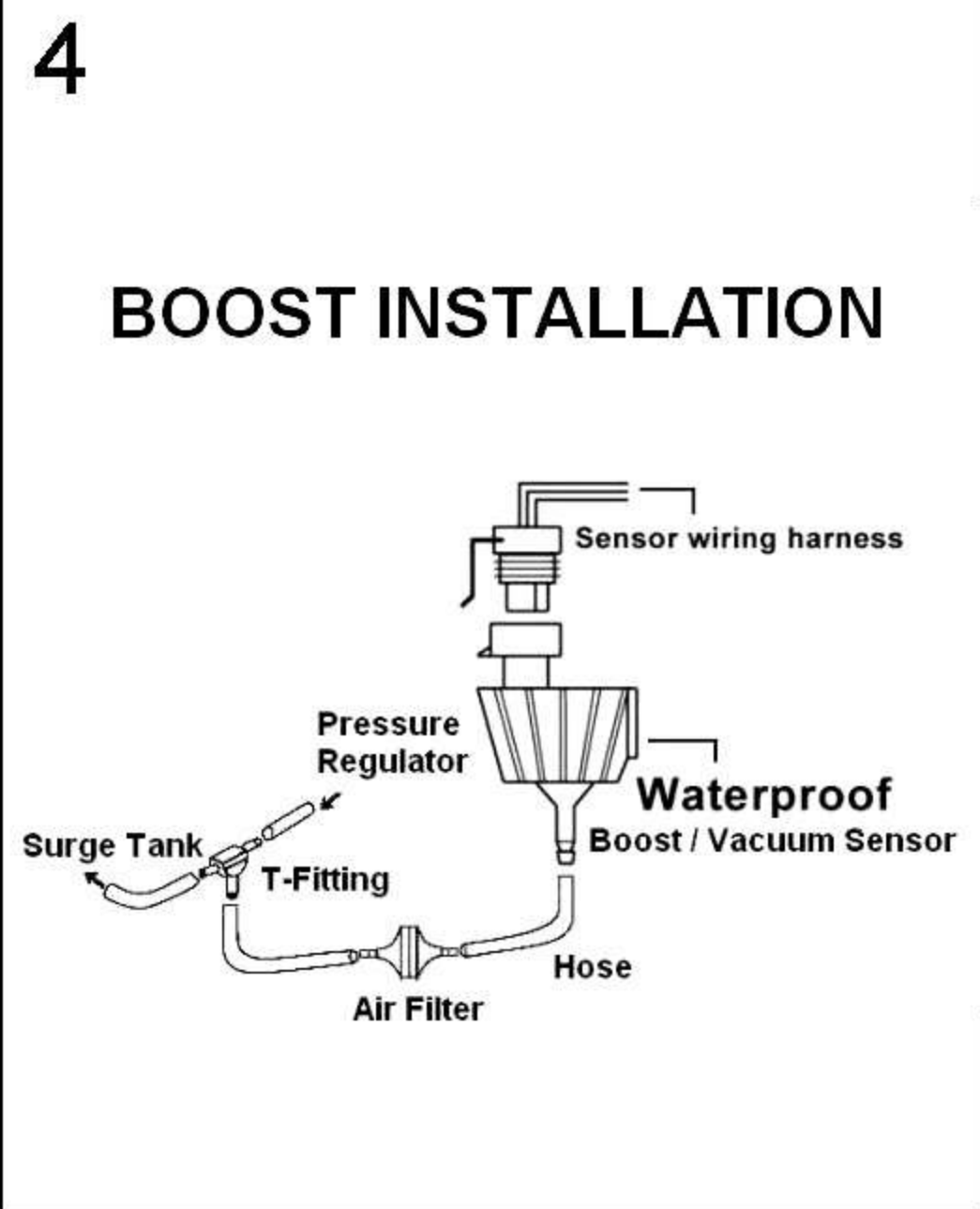
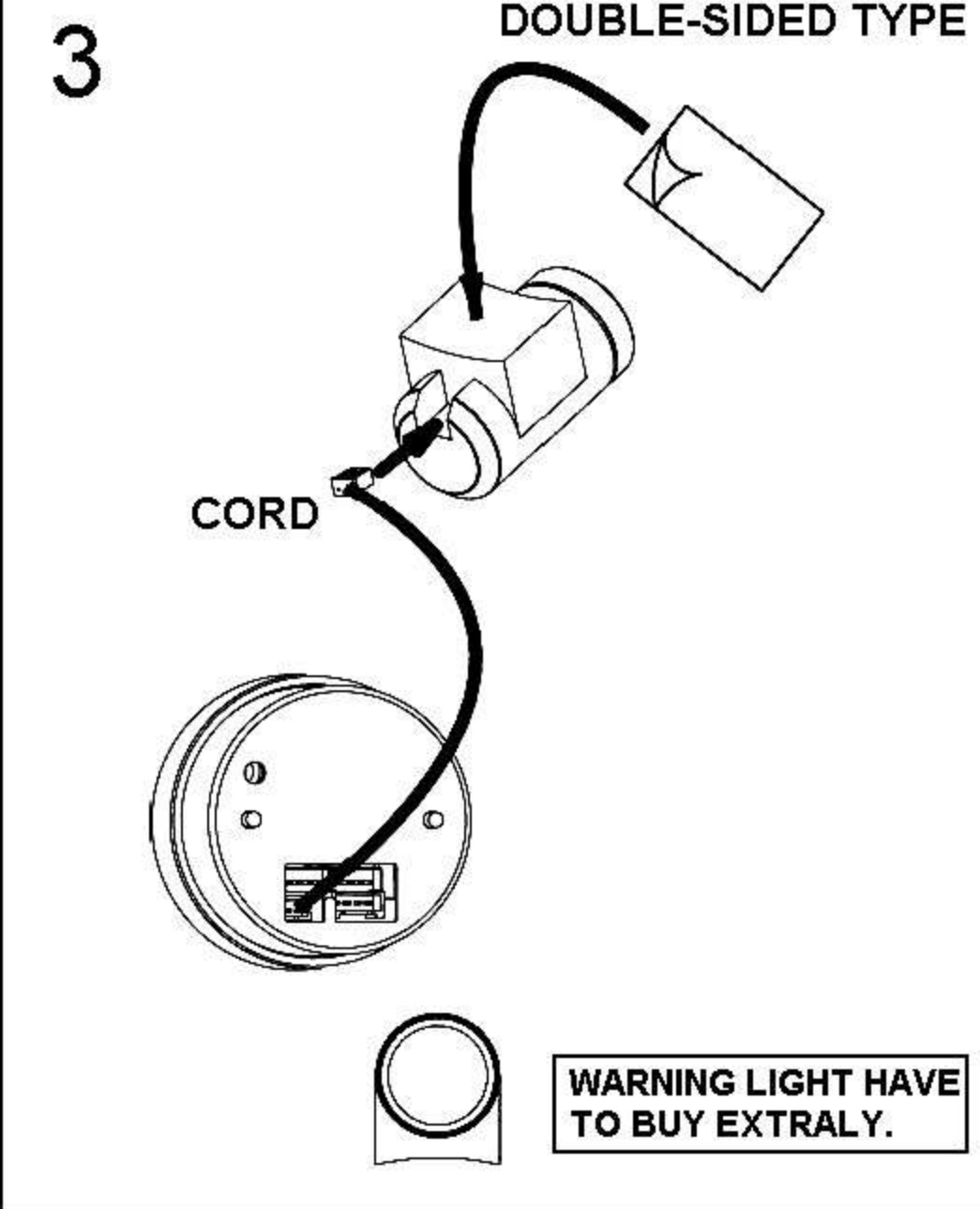
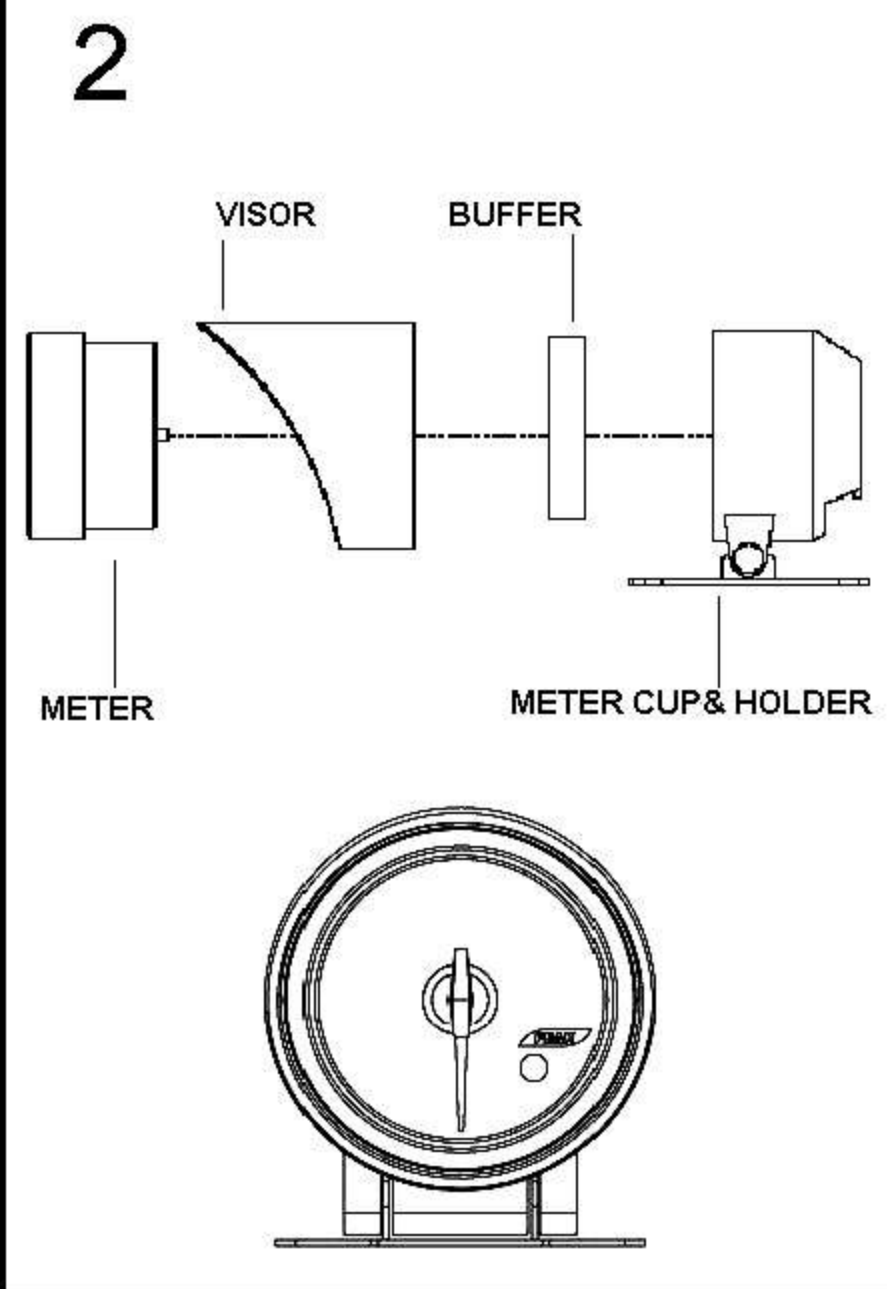
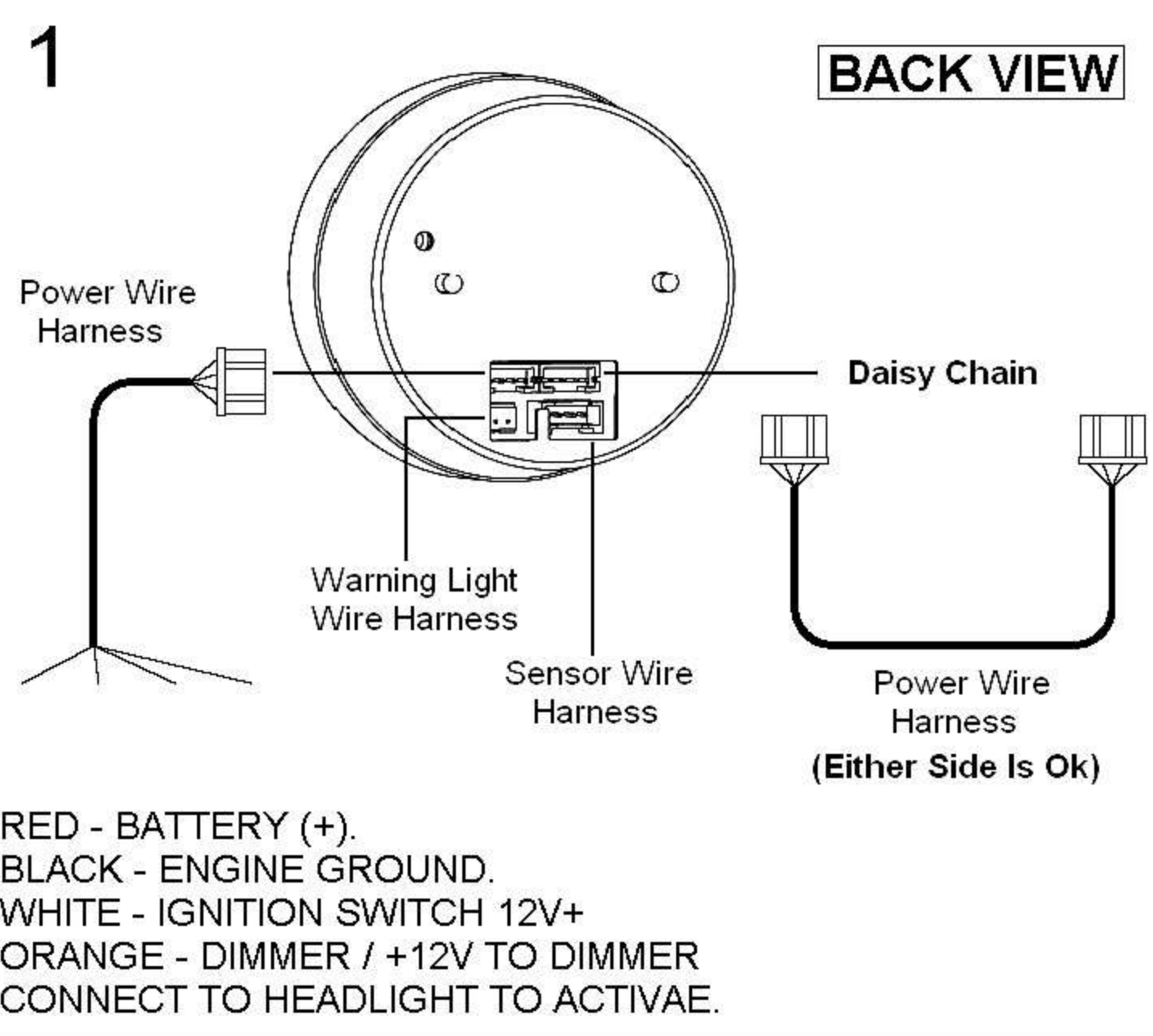

**Note: The remote-controller have to buy extraly.**